

BTT310



Smart GNSS/GSM/TEMINAL
with Internal antennas, Analog
input, sos function, RS 485 interface
and 5V500mA output.

Overview

Product Name	BTT310
Dimensions	81(L)*43(W)*15.6(T)mm
Weight	53.5g
Positioning Methods	GPS, BDS, Glonass, QZSS, LBS
Product Certification	CE, FCC

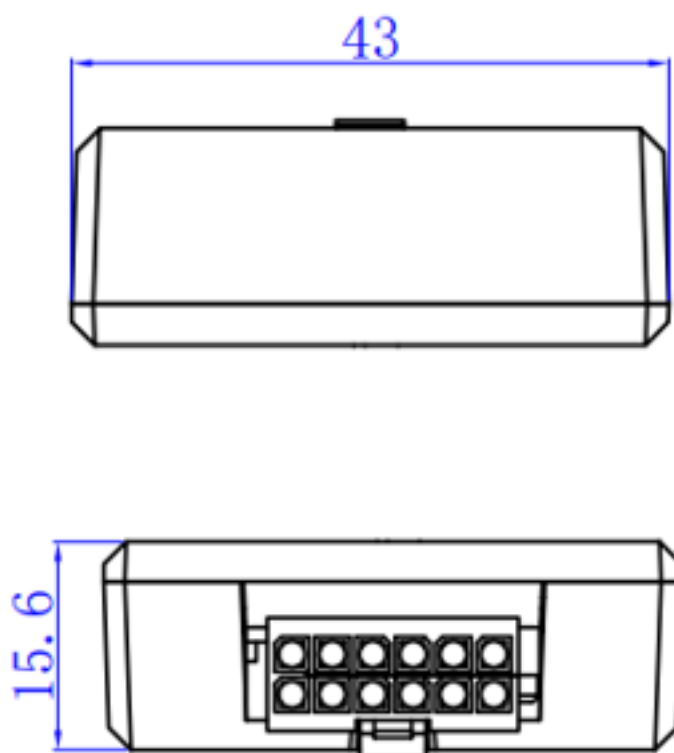
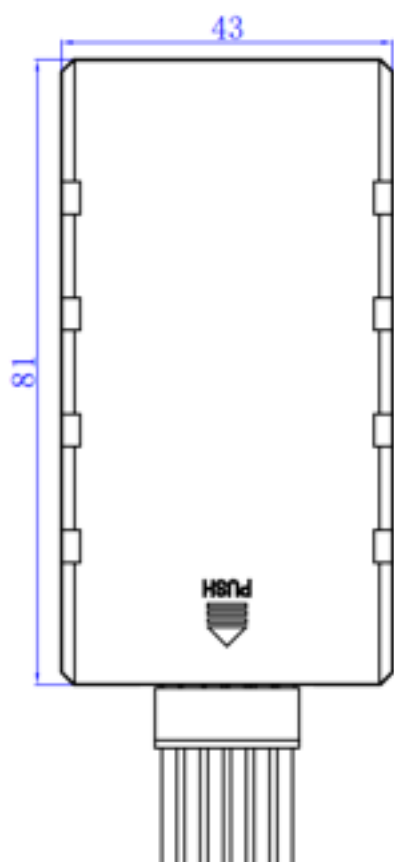

Specification

1 Power Supply

External Power Supply	Built-in Backup Battery
9-90 VDC	140mAh Li-ion Battery

2 Technology

Type	BTT310
Technology	LTE/GSM
Quad Band	LTE-FDD:B1/B3/B5/B7/B8/B20 GSM:900/1800MHz
Antenna	Built-in High Gain Antenna
GPRS Specifications	Class12
Data Path	SMS, Platforms

3 Ready to start

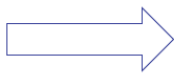
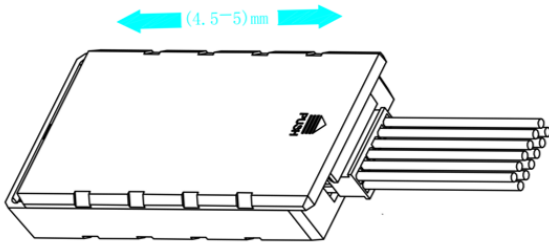

Slide to open

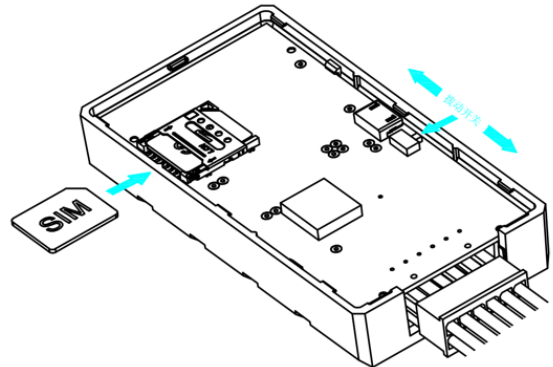

Assembly the SIM card and turn on the switch

Pin Details

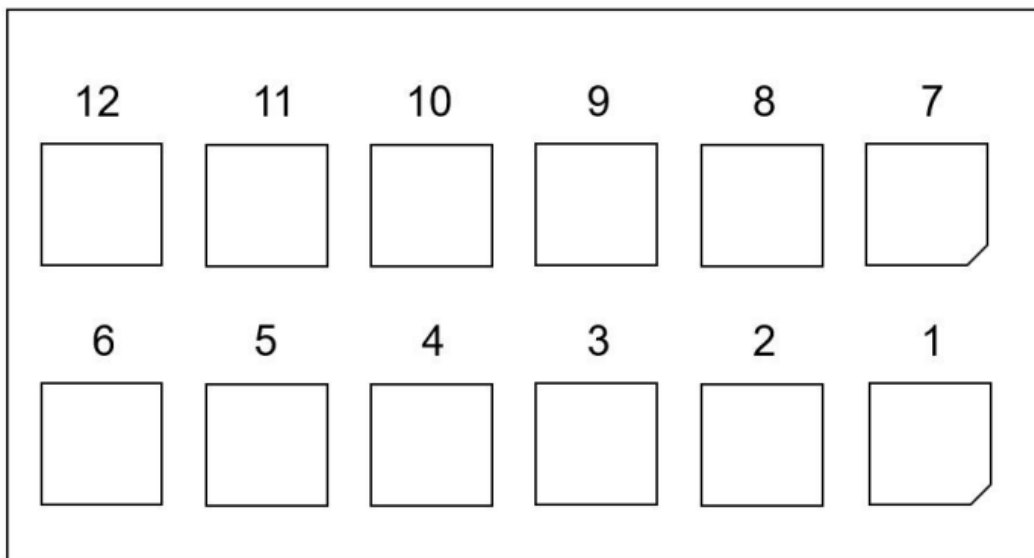

12PIN	11PIN	10PIN	9PIN	8PIN	7PIN
DIN2(SOS)	DIN4	AIN1	DIN3	485B	485A
6PIN	5PIN	4PIN	3PIN	2PIN	1PIN
DO2	1-wire	DO1 (Relay)	DIN1(ACC)	GND	VCC

Wiring Scheme

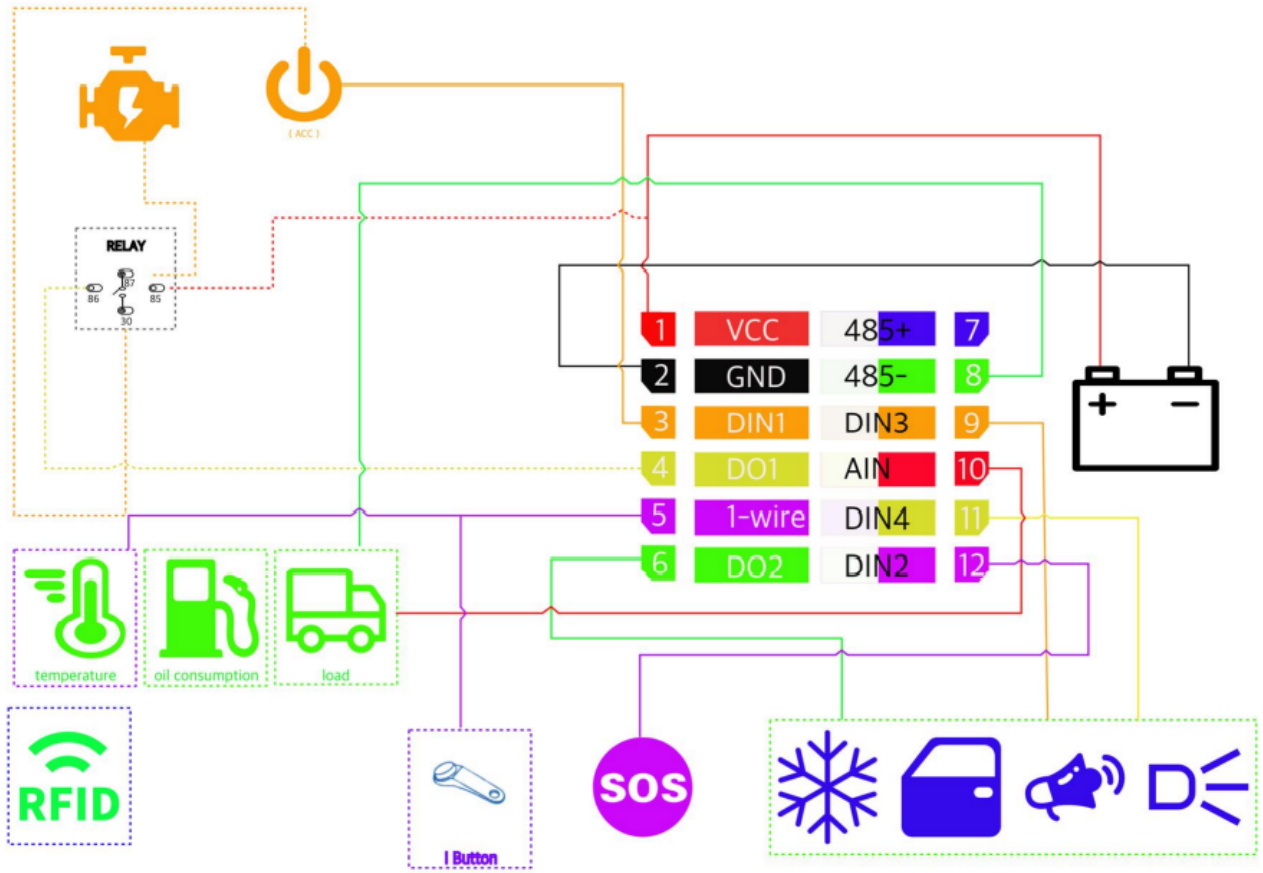

Quick Commands

Function	SMS Command
Backend server parameter settings	SERVER,1,Domain,port,0# SERVER,0,IP,port,0#
Setting the APN	APN,<Internet Name># APN,<Internet Name>[,Username] [,User Password]# Use custom APN parameters to turn off APN adaption. APN# Query the APN parameters currently in use
Centre number setting	CENTER,A,Centre Number#
Enquiry Status	STATUS#
Query parameter settings	PARAM#
GPS data timing interval	TIMER,T1,T2# T1=5~60 s ; ACC ON Status Upload Interval T2=5~60 s ; ACC OFF Status Upload Interval

LED indicator Introduction

Orange (GSM)

Fast Flashing: GSM is initializing
Slow Flashing: GSM signal is normal
Always on: GPRS working
No Flashing: No GSM Signal/SIM Card

Blue (GPS)

Fast Flashing: Searching for GPS signal
Always on: Position captured
No Flashing: GPS sleep
/ GPS not working

Safety Information

This message contains information on how to operate BTT310 safely. By following these requirements and recommendations, you will avoid dangerous situations. You must read these instructions carefully and follow them strictly before operating the device!

- The device uses SELV limited power source. The nominal voltage is +12 V DC. The allowed voltage range is +9 ... +90 V DC. • To avoid mechanical damage, it is advised to transport the device in an impact-proof package. Before usage, the device should be placed so that its LED indicators are visible. They show the status of device operation.
- When connecting the 12 connector wires to the vehicle, the appropriate jumpers of the vehicle power supply should be disconnected.
- Before unmounting the device from the vehicle, the 12 connector must be disconnected. The device is designed to be mounted in a zone of limited access, which is inaccessible to the operator. All related devices must meet the requirements of EN 60950-1 standard. The device BTT310 is not designed as a navigational device for boats.



Do not disassemble the device. If the device is damaged, the power supply cables are not isolated or the isolation is damaged, DO NOT touch the device before unplugging the power supply



All wireless data transferring devices produce interference that may affect other devices which are placed nearby.



The device must be connected only by qualified personnel.



The device must be firmly fastened in a predefined location.



The programming must be performed using a PC with autonomic power supply.



Installation and/or handling during a lightning storm is prohibited.



The device is susceptible to water and humidity.



Risk of explosion if battery is replaced by an incorrect type. Dispose of used batteries according to the instructions.



Battery should not be disposed of with general household waste. Bring damaged or worn-out batteries to your local recycling center or dispose them to battery recycle bin found in stores.